

BUSTER 950

(EN) Instruction Manual
(Translation of the Original Version)



2023-06-19

Meclean BV
Mr. F.J. Haarmannweg 29
4538 AN Terneuzen
NETHERLANDS

Tel: +31 (0)115 43 25 30
Mail: info@meclean.eu

1.	Contents, General3
1.1	Contents3
1.2	Proper Use3
1.3	EC Conformity Declaration3
1.4	Rating Plate3
1.5	Explanation of Symbols4
2.	Construction, Function, Technical Data4
2.1	Packing Contents4
2.2	Function4
2.3	Operating and Functional Components4
2.4	Technical Data5
3.	Safety6
3.1	Safety Instructions6
3.2	Symbols in the Operating Manual6
3.3	Symbols on the Sweeper6
3.4	Safety Equipment6
4.	Setting Up/Before Start Up/Start Up/Transport7
4.1	Unpacking the Sweeper7
4.2	Waste Disposal / Recycling7
4.3	Adjusting the Transport Bar7
4.4	Fitting the Side Brushes7
4.5	Opening the Front Panel8
4.6	Closing the Front Panel8
4.7	Before Start Up/Transport Weight8
4.8	Batteries / Charger9/10
4.8.1	Fitting Batteries and Connecting9
4.8.2	Battery Connection Diagram9
4.8.3	Charging Batteries / Battery Charge Indicator (LBF)10
4.8.4	Charger10
4.8.5	Removing Batteries10
4.9	Start Up11
5.	Operation11
5.1	Starting Sweeper11
5.2	Driving Sweeper11
5.3	Sweeping Operation with Side Brushes, Roller Brush and Fan11
5.4	Switching Off Sweeper12
5.5	Transporting the Machine12
5.6	Cleaning the Dust Filter12
5.7	Emptying the Dirt - Hopper12
6.	Troubleshooting13
7.	Care and Maintenance (Minor Repairs)12/13
7.1	General Cleaning14
7.2	Changing / Cleaning the Filter14
7.3	Inserting the Filter15
7.4	Tipping the Sweeper15
7.5	Changing the Roller Brush15
7.6	Setting Sweeping Roller Brush Clearance16
7.7	Changing the Side Brushes16
7.8	Setting the Side Brushes16
7.9	Changing the Front Sealing Rubber16
7.10	Changing the Side Sealing Rubber17
7.11	Setting / Replacing the Drive Bowden Cable17
7.12	Setting / Replacing the Side Brush Bowden Cable17
7.13	Important Spare Parts and Consumables / Contact17
7.14	Contact Data18
7.15	Maintenance Work / Maintenance Table18
8	Shut Down, Dismantling, Disposal19
9	Circuit Diagram20

1 CONTENTS / GENERAL

1.1 CONTENTS

This operating manual contains instructions for using the sweeper.

Carefully keep the operating manual so that you can refer to it later.

Our products are being continuously improved. Design changes after going to print may therefore not be considered. If you have any questions, please contact our Service department (for contact details, see page 17).



Carefully study the operating manual and the general safety instructions before you unpack the machine any further or undertake first start up.

The operating manual is to be read attentively and followed by any person that operates the sweeper.

1.2 PROPER USE

Only use the sweeper according to the specifications in this operating manual.

The sweeper is only intended for sweeping hard standing areas (e.g.: car parks, pavements, warehouses). The sweeping environment must not be wet.

The sweeper must only be operated by reliable, instructed personnel.

Prevent it from being used by children, young people and other unauthorised persons, e.g. by removing the key after use.

Any other usage beyond this is deemed to be improper use (see "Safety Instructions", chapter 3). The manufacturer is not liable for any damage resulting from this.

The user is solely responsible for the risk.

Proper use also includes following the operating manual, the safety instructions and keeping to the servicing and maintenance specifications.

Only operate in expressly assigned routes and places.

Observe the maximum climbing ability specified in the technical data and maximum possible slope inclination for operating across slopes. Due to an abrupt change of direction, particularly on slopes, the sweeper may tip. Adapt your operating manner and speed to the conditions.

Follow the instructions on suitable ground (asphalt, screed, industrial floors, concrete, paving stones etc.)



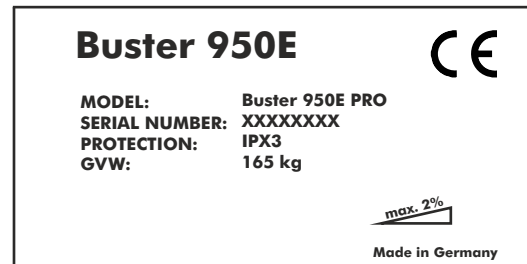
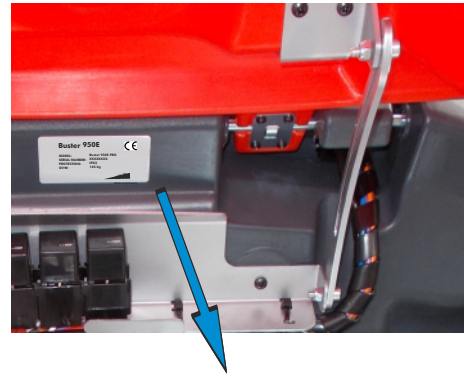

1.3 EC DECLARATION OF CONFORMITY

1.4 RATING PLATE

The rating plate is attached on the top of the frame below the front panel.



1.5 EXPLANATION OF SYMBOLS

-  **DANGER!**indicates a possibly dangerous situation that can cause death or serious injuries.
-  **CAUTION!**indicates a possibly dangerous situation that can cause minor injuries.
-  **WARNING** ...indicates a possibly dangerous situation that may cause material damage.
-  **INSTRUCTION**indicates important information.

2 CONSTRUCTION, FUNCTION, TECHNICAL DATA

The TwinSweep Buster 950E is a battery-operated, hand-driven pedestrian-controlled vacuum sweeper fitted with the tandem roller system (TRS).

The TRS allows large sweeping materials to be swept up without difficulty. The sweeper has a powerful vacuum function.

2.1 PACKAGING CONTENTS

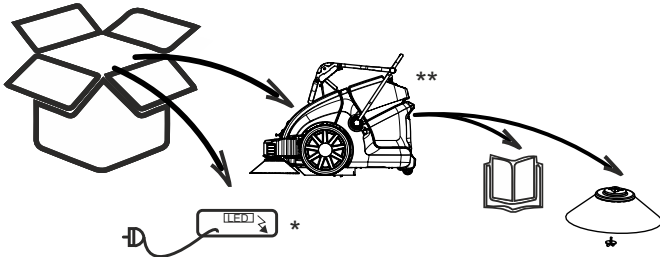

- * External charger only for Basic version
- ** The machine may differ from the illustration

2.2 FUNCTION

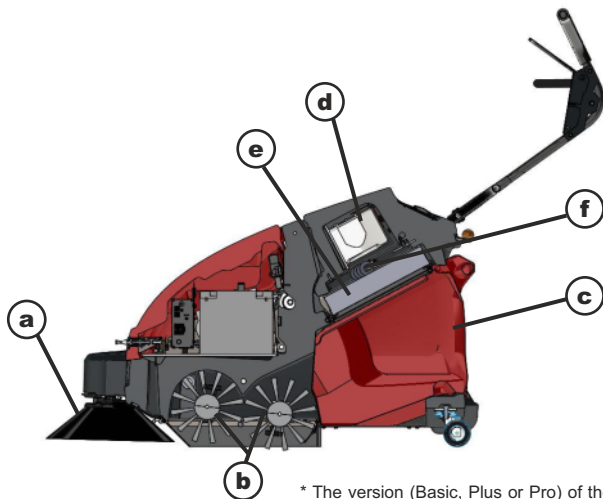

* The version (Basic, Plus or Pro) of the machine may differ from the illustration

In the tandem roller system (TRS), sweeping materials are first conveyed by means of the side brush (a) from the corners and edges of the sweeping area into the centre of the machine and therefore towards the two counter-rotating roller brush (b).

From this, the sweeping material is taken up and conveyed into the dirt-hopper (c) situated at the back.

The dust stirred up by the sweeping process is vacuumed up by a vacuuming system (fan) (d), filtered by flat-pleat filter (e) and thus separated from the clean air.

Electro-mechanical filter cleaning (f) removes the dust caked onto the flat-pleat filter and allows this to drop into the dirt-hopper.

2.3 OPERATING AND FUNCTIONAL COMPONENTS

Overview:

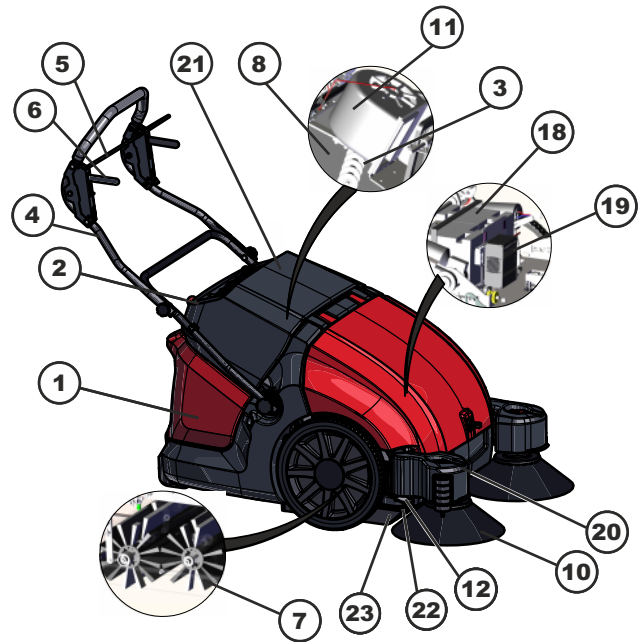

* The version of the machine may differ from the illustration

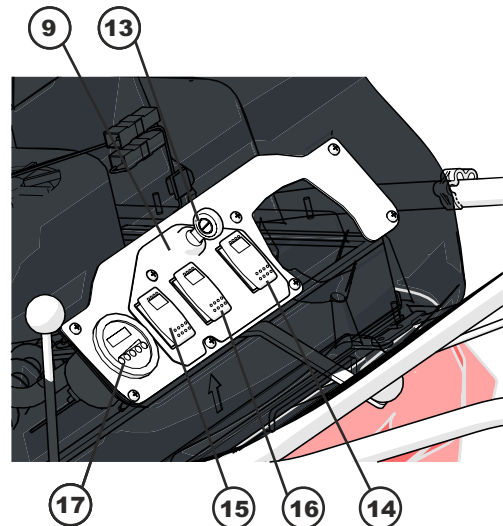

- | | |
|---|--|
| 1 Dirt-Hopper | 13 Key Switch (Main Switch) |
| 2 Shaker rod (Basic + Plus) | 14 Side Brush Switch |
| 3 filter cleaning
Mechanical (Basic + Plus)
electrical "by touch of a button" (Pro) | 15 Roller Brush Switch |
| 4 Transport Bar | 16 Fan/Shaker Selector (Only Pro) |
| 5 Transport Lever | 17 Charge Indicator/Hours Meter |
| 6 Brush Selector | 18 Battery/Batteries (Basic 1x50Ah /
Plus 1x75 Ah / Pro 2x50Ah) |
| 7 Roller Brush | 19 Charger on Board
(only Plus and Pro, Basic External Charger) |
| 8 Flat-Pleat Filter | 20 LED Front Light (only Pro) |
| 9 Control Panel | 21 Filter cover |
| 10 Side Brushes | 22 Side Sealing Rubber |
| 11 Vacuuming System (Fan) | 23 Front Sealing |

2.4 TECHNICAL DATA

Technical data				
		Basic	Plus	Pro
Machine data				
Length x width x height (pusing handle unfolded) max	mm	1085x820x1200		
Length x width x height (without pusing handle)	mm	1085x820x710		
Length x width x height (pusing handle folded in)	mm	1085x820x790		
Weight (without batteries)	kg	83	90	94
Weight (with batteries)	kg	98	114	124
Permissible overall weight	kg	165		
Driving and sweeping speed	km/h	4		
Climbing capability (max.)	%	2		
Incline (max.)	%	2		
Center-brush length	mm	500		
Center-brush diameter	mm	195		
Side-broom diameter	mm	354		
Theoretical sweeping performance (at 4 km/h)	m ² /h	3600		4400
Effective sweeping performance (70%)	m ² /h	2520		3080
Sweeping width with folded-out side-brooms (mm)	mm	--		1100
Sweeping width with folded-in side-brooms (mm)	mm	900		
Sweeping width - center brush	mm	500		
Dirt-Hopper size	l	75		
Permissible maximum payload Dirt - Hopper	kg	40		
IPX-protection type	--	IPX 3		
Battery				
Type	--	12V 50Ah (C20) AGM	12V 75Ah (C20) AGM	2x 12V 50Ah (C20) AGM
Capacity	Ah	50 (20h)	75 (20h)	100 (20h)
Weight	kg	15,1	24,2	30,2
Charging time for fully discharged battery(80%)	h	4	6	8
Run time up to	h	2,5	2	2,5
Charger				
Charger	--	External	On board	On board
Mains voltage	V~	100-240V AC		
Output voltage	V	12		
Charging current	A	10		
Mains frequency	Hz	50/60		
Electrical fuses				
Central relay	A	70		
Circuit breaker forward traction	A	--	25	25
Circuit breaker center-brush	A	20	20	20
Circuit breaker side-broom	A	10	10	10
Circuit breaker filter-shaker	A	--	--	10
Circuit breaker suction system	A	15	15	15
Deep discharge protection	--	Battery indicator (LBF)		
Filter- und vacuum-system				
Filter cleaning		mechanical		electrical
Filter area	m ²	2,5		
Filter class	--	M		
Working conditions				
Operating temperature	°C	-15 bis +40		
Charging temperature	°C	-15 bis +40		
Values according to EN 60335-2-72				
Sound pressure Level L _{PA}	dB(A)	62		
Uncertainty K _{WA}	dB	3		
Sound power level L _{WA} + Uncertainty K _{WA}	dB(A)	83		
Vibration	m/s ²	<2,5		

3 SAFETY

3.1 SAFETY INSTRUCTIONS

As well as the operating manual and the binding regulations for accident prevention applicable in the country of usage and at the place where it is deployed, recognised rules for safety and expert working, and environmental protection, are also to be followed.

Safety Instructions for Operation

- The machine is to be inspected before usage for its perfect condition and operational safety. If it is not in perfect condition, it must not be used.
- In particular, have any errors that may affect safety rectified immediately.
- Operating the machine in buildings at risk of explosion is prohibited.
- Sweeping up of flammable, toxic or explosive materials and combustible gases or undiluted acids and solvents, burning or smouldering objects is prohibited.
- The device is not suitable for accepting fluids, ropes, twines, wires or similar items.
- Only use the machine with the dirt-hopper inserted to prevent injuries due to parts being projected.
- Do not make any alterations or additions to the machine without the approval of the manufacturer.
- Persons (including children) who, due to their physical, sensory or mental capacities or their inexperience or lack of knowledge, are not capable of using the machine safely must not use this machine without the supervision or instruction of a responsible person. Children must be supervised to ensure that they do not play with the machine.
- Caution: Loose items of clothing may be drawn into rotating parts and cause serious or fatal injuries.
- Transporting loads with the sweeper is not permitted.
- Observe the maximum climbing ability specified in the technical data and maximum possible slope inclination for operating across slopes. The equipment may tip, particularly on slopes. Adapt your operating manner and speed to the conditions.
- The machine is not permitted for use on roads.

Safety Instructions on Batteries

- The operating instructions of the battery manufacturer for their product and the specifications of the legislator on handling batteries are to be followed.
- Charge flat batteries directly after usage and only keep in well-ventilated rooms.
- Keep away from naked flames and electrical sparks in the charging area, as a highly-explosive gas mixture can be produced when charging batteries.
- Always keep batteries clean and dry to avoid leakage currents. Never short circuit the battery terminals.

- To avoid damage to health, smoking, eating and drinking in the area of the battery charging station is to be avoided.
- The battery must only be charged with the front panel open and secured by the cover holder.
- Ensure safe and environmentally-friendly disposal of operating and auxiliary materials, as well as replacement parts, particularly batteries!



Safety Instructions for Care and Maintenance

- Before cleaning and maintaining the equipment, replacing parts or changing to a different function, the equipment is to be switched off and the ignition key is to be pulled out.
- Spare parts must correspond to the requirements laid down by the manufacturer. This is always guaranteed for original spare parts.
- Accessories and spare parts must only be installed by an authorised customer service department.
- For work on the electrical system, the battery is to be disconnected.
- The equipment must not be cleaned with a hosepipe or high-pressure water jet (risk of short-circuits or other damage).
- Repairs must only be made by the permitted customer service centres or by experts in this field familiar with all the relevant safety regulations.
- Follow the safety review according to the locally-applicable regulations for mobile industrial equipment.
- Always wear suitable gloves when working on the equipment.

3.2 SYMBOLS IN THE OPERATING MANUAL

	WARNING! CAUTION! DANGER! THE INSTRUCTIONS DESCRIBED MUST BE FOLLOWED
	WEAR BREATHING PROTECTION!
	WEAR PROTECTIVE GOGGLES!
	WEAR GLOVES!

3.3 SYMBOLS ON THE SWEEPER

	WARNING! CAUTION! DANGER! THE INSTRUCTIONS DESCRIBED MUST BE FOLLOWED!
	FOLLOW THE OPERATING INSTRUCTIONS!

3.4 SAFETY EQUIPMENT

- Safety equipment is to be inspected for functioning before starting work.
- Only allow the sweeper to be switched on if the following conditions are met:
 - a) The start key is in the ON position.
 - b) The filter box is closed
 - c) The dirt-hopper is closed. The power supply to the sweeper is interrupted when:
 - a) The start key is switched to the OFF position
 - b) The filter box is open
 - c) The dirt-hopper is open

The safety equipment attached to the machine must not be bypassed or put out of operation.

4 SETTING UP / BEFORE START UP / OPERATING / TRANSPORT

4.1 UNPACKING THE SWEEPER

i **Instruction** Look out for damage in transit and if there is any, indicate this to your specialist dealer without delay.

- Remove the box.
- Remove wooden blocks for securing the wheels.
- Stop the transport bar in the desired position using the star handle.

See also: *PACKING CONTENTS* → Chapter 2.1

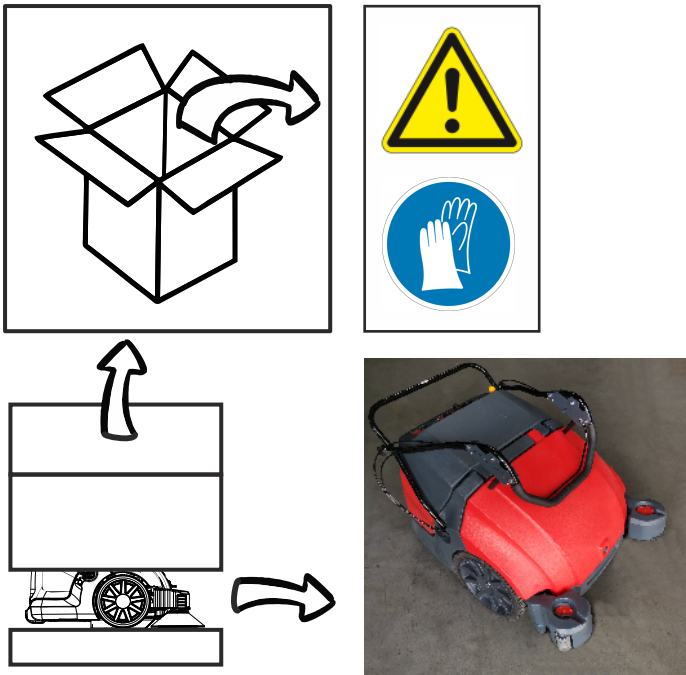

4.2 WASTE DISPOSAL / RECYCLING



Recycling packaging materials. Do not dispose of packaging materials in normal waste but forward for reprocessing.

For the disposal of all packaging materials, the disposal conditions specific for the location are applicable.

See also: *Putting Out of Operation / Recycling* → Chapter 8

4.3 ADJUSTING THE TRANSPORT BAR

- Undo star screws of the raster fastening on the frame (I)
- Fold out lower transport bar (II)
- Retighten star screws (III)
- Undo star screws on the upper transport bar (IV)
- Set out the upper transport bar
- Adjust the transport bar for the operator using the star screws (III + IV + VI)
- Tighten all star screws (VII)



4.4 FITTING THE SIDE BRUSHES

Put the side brushes onto the take-up of the driver (Fig. 2) and screw tight with the wing bolts (includes: washer, serrated lock washer, O-ring and wing bolt - Fig. 3).

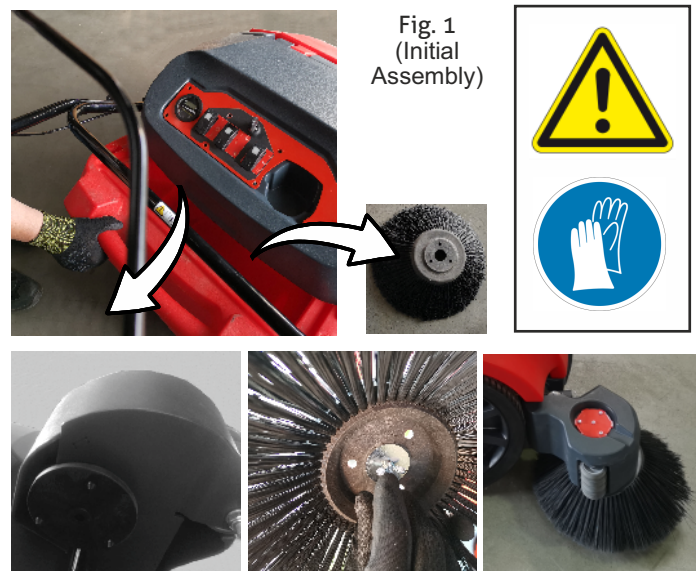

Fig. 2

Fig. 3

Fig. 4

4.5 OPENING THE FRONT PANEL

The front panel is unlocked with a panel key (rotate clockwise).

Remove the key and open the front panel and pull to its highest position, the panel will engage automatically.



4.6 CLOSING THE FRONT PANEL

Raise the front panel slightly to close it and push the backplate (holds the equipment panel) back slightly and close. The equipment panel engages automatically.

There is a risk of crushing. When closing remove all body parts from the danger area.

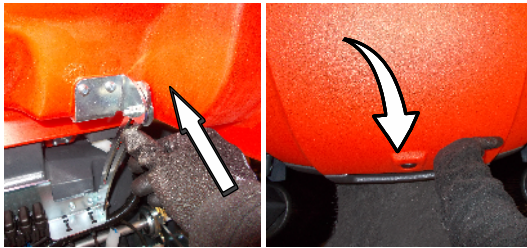

4.7 BEFORE START UP/ TRANSPORT WEIGHT

	WARNING! CAUTION! DANGER! THE DESCRIBED INSTRUCTIONS MUST BE FOLLOWED!
	FOLLOW THE OPERATING MANUAL OF THE SWEEPER!

⚠ DANGER!

Risk of injury and/or damage! Take care of the weight of the equipment when charging!

TRANSPORT WEIGHT			
Version	BASIC	PLUS	PRO
WEIGHT empty	83	90	94
WEIGHT with batteries	98	114	124

⚠ CAUTION! Only operate with the front panel and refuse container closed.

⚠ CAUTION! Charge the battery fully!

• Make sure you are satisfied that the machine has been supplied undamaged and complete.

See also **UNPACKING THE SWEEPER** → **Chapter 4.1**

• If you have any complaints, contact your specialist dealer or our Service department.

• Read the **SAFETY INSTRUCTIONS** → **Chapter 3.1**

• Read the operating manual of the charger provided. Take note of the warning instructions for the battery!

- Connect the terminal (red cable) to the plus pole of the battery.
- Push the side brushes on the driver and screw tightly.
- Close the equipment panel and the refuse container
- Stop the transport bar using the star handle into the desired position.

4.8 BATTERIES / CHARGER

Safety Instructions on Batteries

You must note the following warning instructions for handling batteries:

	WARNING! CAUTION! DANGER! THE INSTRUCTIONS DESCRIBED MUST BE FOLLOWED!
	FOLLOW THE INSTRUCTIONS ON THE BATTERY, IN THE USER INSTRUCTIONS FOR THE BATTERY AND THE OPERATING INSTRUCTIONS.

To do this, you must read the **General Safety Instructions**, particularly the **Battery Warning Instructions Chapter 3!**

Recommended Batteries

Please use original spare parts and contact Customer Services.

4.8.1 FITTING BATTERIES AND CONNECTING

		WARNING! - WEAR GLOVES WHEN WORKING IN THE AREA OF THE BATTERY TO AVOID INJURIES
--	--	--

- Open front panel
- Undo the charger holder (star handle) and fold upwards.
- Place batteries onto the mounting plate (2).
- Connect any connection cable of the battery.
- Secure batteries with the relevant holding strap (1).
- The terminal (red cable) is to be attached to the plus pole (+) of the battery.
- Attach the connection table (short red cable only for 2 batteries) respectively to the plus pole (+).
- Terminal to the minus pole (-)
- Only use batteries with pole cover!

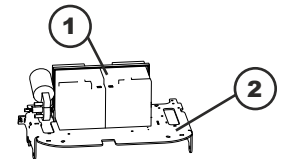

* The battery/ies may differ from the illustration

i INSTRUCTION Attach the batteries according to the specification

See → (Fig. 1-2 - CONNECTING BATTERIES Chapter 4.8.3)

i INSTRUCTION Charge the batteries before putting the equipment into operation! (Ch. 4.8.3 +4.8.4)

i INSTRUCTION Charge the battery fully!

4.8.2 BATTERY CONNECTION DIAGRAM

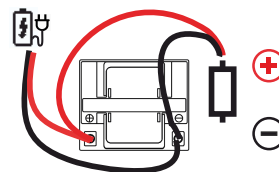

Fig. 1: Battery Version Basic + Plus

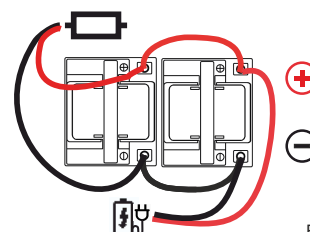

Fig. 2: Batteries Pro Version

4.8.3 CHARGING BATTERIES

⚠ DANGER → Risk of injury, the charger must only be put into operation if the mains cable is not damaged. A damaged mains cable is to be replaced without delay by the manufacturer, Customer Services or a qualified person.

⚠ DANGER → Danger of electric shock. Follow mains and use the correct fuse. Only user charger in dry rooms with sufficient (i.e. open front panel) ventilation. Observe charging times.

⚠ DANGER → Risk of injury! Follow the safety instructions when handling batteries. Follow usage instructions of the charger manufacturer.

Battery charge indicator

i INSTRUCTION The equipment is fitted as standard with maintenance-free batteries.



Operational	lit yellow
Charge battery	lit red
Protection against deep discharge	flashes (equipment shuts down)

4.8.4 CHARGER

i INSTRUCTION Read the operating manual of the charger manufacturer.

i INSTRUCTION Batteries must only be charged at room temperature.

Charging on-board charger

- Open the equipment panel
- Plug the mains plug of the charger into the socket.

i INSTRUCTION The charger is electronically controlled and stops charging automatically. All functions of the sweeper are automatically interrupted during charging.

- If the battery or batteries is/are charged, the yellow light of the charger is lit.
- The battery is fully charged if the light of the charger is lit green.



After charging, unplug the on-board

- charging unit mains cable.
- Unwind the mains cable from the charger cable bracket.
- Close the equipment panel.

Charging external charger

- Open the equipment panel
- Plug in the charger charging cable into the charging terminal of the sweeper.
- Plug the mains plug of the charger into the socket and switch on the charger.

After charging, unplug the external charger

- Switch off the charger and disconnect from the mains.
- charging cable on the equipment.
- Close the equipment panel.

4.8.5 REMOVING BATTERIES

- Open front panel. (See Chapter 4)
- Disconnect any charging plug
- Disconnect terminal from minus pole (-)
- Disconnect terminal from plus pole (+)
- Unscrew battery connection cable.

- Undo the charger holder (star handle) and fold upwards.
- Undo holding strap.
- Remove battery.
- Dispose of used batteries according to the applicable provisions (see Ch. 3 Environmental Protection).

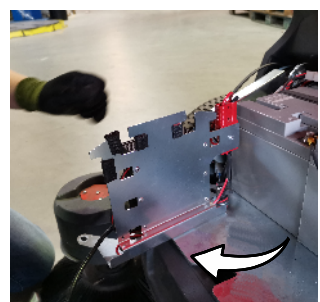
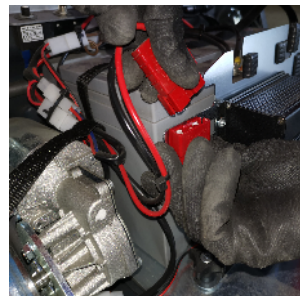

4.9 START UP

General Instructions

⚠ DANGER! Risk of injury! Switch off equipment before removing the dirt-hopper.

⚠ CAUTION! Only operate with the front bonnet and dirt-hopper closed.

i INSTRUCTION
MUST BE FOLLOWED! → BEFORE START UP , chapter 4.7

- Make sure you are satisfied that the machine has been supplied undamaged and complete. See → BOX CONTENTS, chapter 2.1
See → UNPACKING, chapter 4.1
- If you have any complaints, contact your specialist dealer or our Service department.

5 OPERATION (USAGE AND OPERATION)

MUST BE FOLLOWED!

You must only carry out the work described in this chapter if you have completely read and understood the operating manual, particularly Chapter 1-4.

i INSTRUCTION Safety equipment is to be inspected for functioning before starting work

See also → Safety, chapter 3

⚠ DANGER! → If the equipment is used for extended circulatory disorders in your hands due to vibrations may be caused. A generally-applicable usage time cannot be specified, as this depends on several influencing factors: These include a firm grip, low ambient temperature and personal disposition. It is recommended that you take regular breaks, and put the driving bar in an optimum position.

i INSTRUCTION
Please adjust driving speed to the conditions (different ground surface, type and amount of sweeping material), to obtain a good sweeping result.

i INSTRUCTION
When in operation, the dust filter must be cleaned at regular intervals and as required.

i INSTRUCTION
When in operation, the dirt-hopper must be emptied at regular intervals and as required.

See also → CLEANING DUST FILTER , CHAPTER 5.8

See also → EMPYING DIRT-HOPPER, , CHAPTER 4.8.2

5.1 STARTING SWEEPER

- Put the key into the key switch and turn it clockwise to the "ON" position. The drive motor starts.

5.2 DRIVING SWEEPER

- Pull drive lever → The sweeper moves forwards. The drive speed is according to the lever setting steplessly controllable.
- Releasing the drive lever → stops the sweeper.
- The sweeper may also be pushed without the drive.

Running Over Obstacles

- Fixed obstacles up to a height of 45mm may be run over slowly and carefully.
- Obstacles must always be run over with a ramp to protect the machine.

5.3 SWEEPING OPERATION - WITH SIDE BRUSHES, ROLLER BRUSH AND FAN

⚠ CAUTION!

Sweeping material that is too large or non-uniform may be disposed of via the raised filter lid directly into the refuse container.

Risk of dust! Wait 5-10 seconds before opening the filter cover.

⚠ CAUTION!

Do not sweep up any straps, wires or similar as this may cause damage to the sweeping mechanism.

i INSTRUCTION

The fan must absolutely be switched on.

As required:

- Lower the side brushes accordingly (operate pedal)
- Side brush switch in Pos. I (ON), Pos.0 (OFF)
- Sweeping roller switch in Pos. I (ON), Pos.0 (OFF)
- Shaker in Pos. I (ON), Pos.0 (OFF)
- Operate selector (side brushes swivel out to the side)



BASIC Version



Pos I (ON)
Pos 0 (OFF)

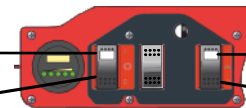

Pos I (ON)
Pos 0 (OFF)



PLUS Version



Pos I (ON)
Pos 0 (OFF)

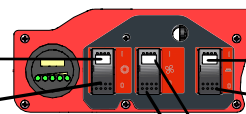

Pos I (ON)
Pos 0 (OFF)



Pos I (ON)
Pos 0 (OFF)



PRO Version



Pos I (ON)
Pos 0 (OFF)

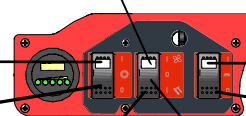

Pos I (ON)
Pos 0 (OFF)

Pos 0 (Fan OFF)

Pos II (Operate shaker)



5.4 SWITCHING OFF SWEEPER

- Set down the machine on a level, dry and protected ground surface.
- Switch off the roller brush, side brushes and vacuuming system.
- Put the key into the "OFF" position (anticlockwise) and pull out.
- Fold in the side brushes.
- Raise the side brushes with the pedal.
- **When setting down, the machine has to be secured against inadvertent movement.**

5.5 TRANSPORTING THE MACHINE

⚠ DANGER! Risk of crushing! Observe the weight of the machine!

i INSTRUCTION! Do not kink any Bowden cables!

- Switch off sweeper and pull out the ignition key.
- Fasten the wheels of the machine with chocks.
- Fasten the machine with tensioning belts or ropes.
- While transporting in vehicles or trailers, the machine has to be secured, according to the relevant applicable guidelines, against sliding and tipping.
- **Two fastening areas for belts:**
 - a) Machine vertically fastened (fastened to the floor as illustrated)
 - b) Machine horizontally fastened (fastened to the wall as illustrated)

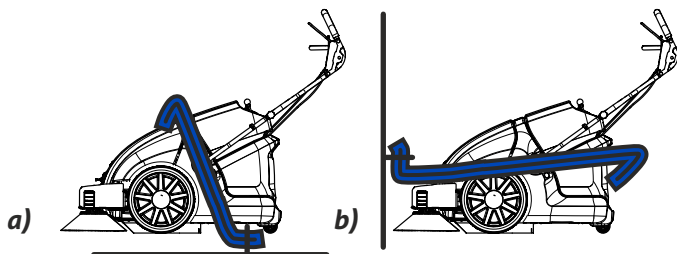

5.6 CLEANING THE DUST FILTER

⚠ CAUTION! → Risk of crushing when closing the filter box.



i Instruction Ensure that the dirt-hopper has been inserted.

- When using the electric shaker (I), operate it for approximately 15-20 seconds.
- When using the mechanical shaker, operate the shaking rod on the ball knob several times (5-10 times) (alternately to the left and right)
- i Instruction** It is recommended waiting 5-10 seconds until the fine dust has settled before emptying the dirt hopper.

5.7 EMPTYING THE DIRT-HOPPER



⚠ DANGER! Risk of injury! Switch off equipment before removing the dirt - hopper.

⚠ CAUTION! Risk of crushing when closing the dirt-hopper!

i Instruction The maximum permitted load (sweeping material) of the dirt-hopper is 40 kg.

i Instruction The refuse container must be emptied at regular intervals to enable perfect sweeping.

- Clean the dust filter regularly.
- Remove the dirt-hopper from the sweeper using the handle on the top.
- Empty the dirt-hopper thoroughly after finishing sweeping work.
- Empty the dirt-hopper into a suitable container.
- Push the dirt-hopper back into the machine.

6 TROUBLESHOOTING

Help for faults		
Fault	Possible cause	Remedy
Device does not start	Battery state $\leq 20\%$	▶ Charge battery
	Battery cable not correctly connected or loose	▶ Check cabling of the batteries and connect correctly
	Safety switch in the filter cover not operated	▶ Close filter cover and insert dirt-hopper correctly.
	Overload or fault with the main relay	▶ Check and replace main relay
	Cause unclear	▶ Notify your dealer or customer services
Drive motor running, but device is not operating	Bowden cable of the traction drive has extended or is not functioning	▶ Check and adjust Bowden cable of the drive
	Lack of power transmission of the drive belt	▶ Check and adjust drive belt of the drive
	Cause unclear	▶ Notify your dealer or customer services
Device stops on a slope when operating	Slope $> 2\%$	▶ Travel on a route with smaller slope
	Bowden cable has extended and the power transmission of the drive belt is no longer sufficient	▶ Check and adjust Bowden cable of the drive
	Lack of power transmission of the drive belt	▶ Check the drive belt of the drive
	Permitted total weight of the machine exceeded by full dirt-hopper.	▶ Empty dirt-hopper.
	Main relay or relay for the drive has been overloaded and is/are faulty	▶ Check relay for the drive
Cause unclear	▶ Notify your dealer or customer services	
Roller brushes are not running	Straps, large packaging residues etc. have been swept up	▶ Turn key switch to "0" (switch off sweeper). Check roller brushes for jammed or picked-up objects such as, for example, straps, cables etc., remove them and check the drums for damage and free running.
	Functional fault of the toothed belt or gear wheels (e.g. toothed belt has come off)	▶ Check toothed belt and gear wheels
	Roller brush motor overloaded (check brushes for free running, as appropriate)	▶ Check and replace relay of the roller brush motor
	Cause unclear	▶ Notify your dealer or customer services
Bad sweeping in the edge region	Side brushes worn	▶ Check for wear, readjust as required or replace the side brushes
	Side brushes have not lowered	▶ Lower the side brushes
	Functioning of the side sealing rubber restricted by wear, a fault or similar.	▶ Replace side sealing rubbers as appropriate
	Cause unclear	▶ Notify your dealer or customer services
Swivelling the brushes in and out not working	Bowden cable has extended or is not functioning	▶ Check and adjust Bowden cable of the side brushes
	Leg spring in the side brush not working (side brush does not swivel out)	▶ Check leg springs in the side brushes for damage and correct seating and replace as necessary
	Side brush jammed by dirt	Clean side brush suspension
	Cause unclear	▶ Notify your dealer or customer services
Sweeper does not sweep correctly	Roller brushes or sweeping tunnel blocked by sweeping material	▶ Check sweeping tunnel for contamination or blockages and remove them
	Roller brushes or side brushes worn or not set correctly	▶ Check roller brushes and side brushes for wear, readjust or replace as required
	Sealing rubber damaged by foreign bodies or running over obstacles without a ramp	▶ Check front, side and rear sealing rubber for damage and correct seating and replace as necessary
	Roller Brushes are not installed according to their direction of rotation	▶ Remove roller brushes and fit according to the direction of rotation
	Cause unclear	▶ Notify your dealer or customer services
Device raises dust	Dust filter no longer cleaned	▶ Check, clean or replace dust filter
	Sealing rubber faulty, so that the vacuuming system cannot work properly	▶ Check front, side and rear sealing rubber for damage and correct seating
	Dirt-hopper is full	▶ Empty dirt-hopper.
	Sealing section fastened wrongly or faulty	▶ Check sealing section on the filter cover and replace as
	Sweeping tunnel blocked by bulky sweeping material so that no sweeping material can be transported into the dirt-hopper any longer	▶ Remove contaminations or blockages in the sweeping tunnel
	Cause unclear	▶ Notify your dealer or customer services
Electrical fault	Overload or wear of electrical components or cause unclear	▶ Notify your dealer or customer services

7 Care and Maintenance (No Repair)

Regular maintenance of the sweeper is useful for the serviceability of the machine, its components and the sweeping result. As a result of the following described and regularly undertaken maintenance work, the lifetime of the machine can be extended.

⚠ DANGER → There is a risk when cleaning. During cleaning, always wear a dust protection mask, as well as protective goggles and gloves.

i INSTRUCTION
Repair work is only to be carried out by permitted customer service centres or specialists for these machines, familiar with all the safety-relevant regulations.

i INSTRUCTION For any care or maintenance:
Set down the machine on a level surface.
Secure the machine from rolling away.
Always switch off the machine and pull out the ignition key.

i INSTRUCTION For work on the electrical system, disconnect the battery.

7.1 GENERAL CLEANING

⚠ CAUTION! There is a risk of damage to the machine. The sweeper must not be cleaned with a hosepipe or high-pressure water jet. There is a risk of damage to the machine or the electric.



7.2 CHANGING / CLEANING FILTER

⚠ CAUTION! Before starting to change or clean the dust filter, clean off the dust filter and empty the refuse container. Wear dust protection mask and protective goggles when working on the filter system. Follow the safety instructions for handling fine dust!

i INSTRUCTION Clean the dust filter before changing

i INSTRUCTION Empty the refuse container before changing

See → *CLEANING DUST FILTER, chapter 5.6*

See → *SWITCHING OFF SWEEPER, chapter 5.4*

See → *EMPTYING REFUSE CONTAINER, chapter 5.7*

- Start mechanical or electrical filter cleaning.
- Switch off the sweeper, pull out the ignition key.
- Raise the filter cover until this engages in the backplate.
- Hold the filter holder firmly and undo the filter lock on the left and right.
- Slowly release the filter holder inc. filter until this is held.
- Take the filter out of the machine.
- Clean or replace as required.
- As required, **carefully** blow out with compressed air.
- Insert filter again.

See also → *INSERTING FILTER chapter 7.3*

i INSTRUCTION! The filter may be damaged by blowing from from too small a distance from the filter material with too much pressure.



7.3 INSERTING THE FILTER

- Insert filter in the installation direction (see symbol on the filter) into the filter holder.
- Lock the filter on the left and right.
- Remove hand from the risk area to avoid crushing.
- Close the filter cover.

⚠ DANGER! → RISK OF CRUSHING when closing the filter box.



7.4 TIPPING THE SWEEPER

⚠ CAUTION! Risk of injury!

- Put ignition key into the "OFF" position and pull out.
- Open front panel.
- Disconnect batteries and remove.
- Close front panel.
- Put the drive bar into the highest position and fold in drive bar.
- Tip the machine rearwards with the help of a second person (first put steering roller in position - parallel to the direction of running) and set up.

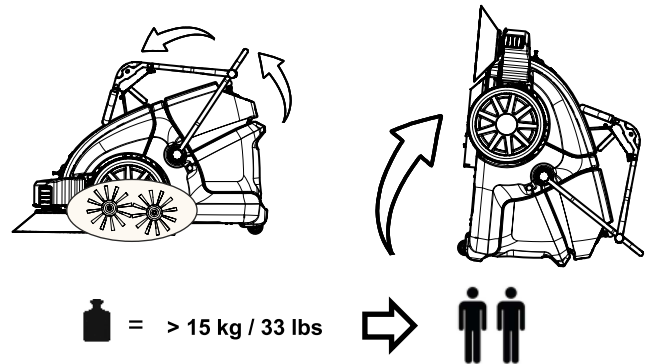
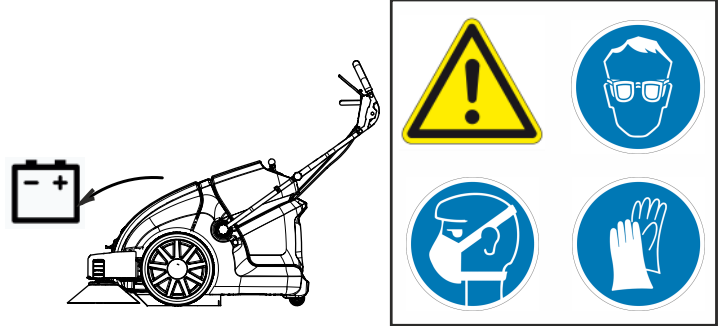

7.5 CHANGING THE SWEEPING ROLLER

- The front drum is not subject to any wear and must not be replaced, except where it is damaged.
- The sweeping roller does not have to be replaced if the sweeping result is visibly worse due to wear of the brushes, and readjustment of the sweeping roller is no longer possible.
- The sweeping roller consists of two segments connected by six screws. Unscrew the screws using a suitable tool and remove the segments individually.
- Insert the new segments into the sweeping roller and fasten again with six screws.
- The direction of movement of the sweeping roller Fig. 2 must be followed.

⚠ CAUTION! There is a risk of damage to the sweeping roller if the brushes become jammed during fitting.

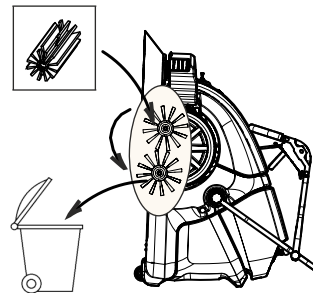

Fig. 1

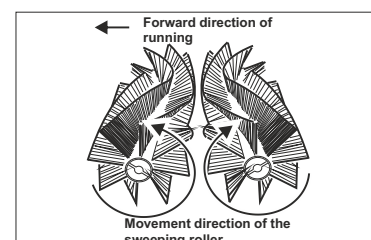
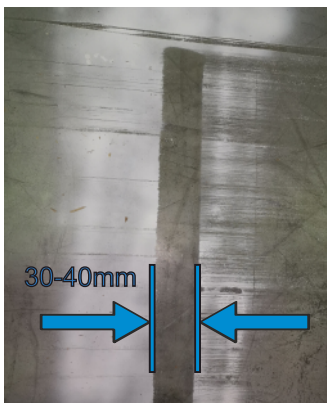
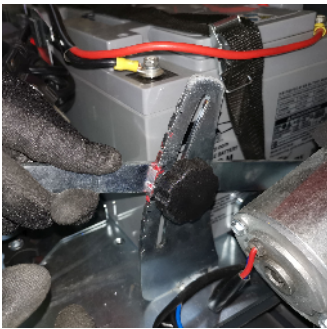

Fig. 2

7.6 SETTING SWEEPING ROLLER CLEARANCE

- Switch off the sweeper.
- Raise the side brushes.
- Operate with the sweeper on level and smooth ground that is recognisably covered with dust, sand or chalk.
- Open the front panel and set the sweeping drum adjustment to the centre position of the whole setting area.
- Close front panel.
- Switch on the machine and allow the sweeping roller to rotate for approximately 15 seconds.
- Run the sweeper from the sweeping clearance.
- The impression of the sweeping roller (=sweeping clearance) must be clearly visible on the ground. The shape of the sweeping clearance forms a uniform rectangle that is between 30 - 40mm wide.
- Lowering the sweeping roller adjustment lever raises the sweeping roller.
- As appropriate, repeat the process until the desired sweeping clearance is reached.
- Close front panel.



7.7 CHANGING THE SWEEPING BRUSHES

The side brushes are subjected to wear. On abrasive surfaces, wear to the brushes is faster than on smooth floors.

It is necessary to change the sweeping brushes if these are worn or damaged. Changing due to wear is necessary if the sweeping result of the side brushes is visibly worsened and it is no longer possible to readjust.

- Put ignition key into the "0" position and pull out.
- Raise the side brushes (transport position)
- Remove the side brushes (undo wing bolt).
- Change the side brushes.
- Put the side brushes on the take-up of the driver and fasten.

See also → FITTING THE SIDE BRUSHES, chapter 4.4 Fig. 2-4

7.8 SETTING THE SIDE BRUSHES

It is necessary to adjust the side brushes if the wear of the brushes visibly makes the sweeping result of the side brushes worse.

- Set down the sweeper onto a level, dry and protected surface.
- Raise the side brushes (transport position)
- Open front panel
- Undo the knurled nuts at the front left and/or right of the side brush adjustment.
- Turn adjustment forwards to lower the side brushes further
- Fasten both knurled nuts again.
- Close front panel.



7.9 CHANGING THE FRONT SEALING RUBBER

The front sealing rubber must be replaced if there are tears or it is worn, to guarantee a good sweeping result.

- Put ignition key into the "OFF" position and pull out.
- Raise the side brushes (transport position).
- Undo all four screws of the front sealing rubber and remove.
- Remove the front seal completely.
- Replace the front sealing rubber.

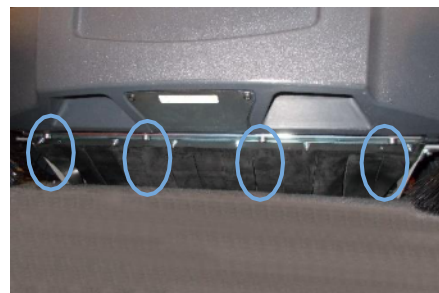

7.10 SETTING / REPLACING SIDE SEALING RUBBER

The basic setting of the side sealing rubber is 1mm.

- Put ignition key into the "OFF" position and pull out.
- Tip the machine as required.
- To set the height, undo the fastenings (2 screws), readjust or replace the side sealing rubber, align and fasten.



7.11 SETTING DRIVE BOWDEN CABLE /CANGING

Readjusting the Bowden cable is required if the driving force of the machine is no longer sufficient.

- Put ignition key into the "0" position and pull out.
- Undo the lock nut.
- Setting/readjusting the Bowden cable
- Screw the lock nut tightly.



7.12 SETTING SIDE BRUSH BOWDEN CABLE /CANGING

Readjusting the Bowden cable is required if the side brush no longer folds in completely.

Folding out is done with springs

- Put ignition key into the "OFF" position and pull out.
- Undo the lock nut under the drive bar cover plate.
- Setting/readjusting the Bowden cable.



7.13 IMPORTANT SPARE PARTS AND CONSUMABLES

Flat filter	Item No. 100223
Sweeping Roller PA 0.4 V	Item No. 110970
Side Brushes PA 0.6	Item No. 110526

7.14 CONTACT DATA

Manufacturer: Meclean BV
Mr. F.J. Haarmanweg 29
4538 AN Terneuzen

Tel: +31 (0)115 43 25 30
Mail: info@meclean.nl

Dealer:

7.15 MAINTENANCE WORK / MAINTENANCE TABLE

i **Instruction:** The following maintenance work must be carried out by instructed and authorised specialist staff at the set intervals.

	<p>CAUTION! In the event that damage to the machine is established, it must not be used until the damage has been remedied by specialist staff.</p>
---	--

⚠ RISK! → Risk of Injury The motor(s) need(s) to overrun for several seconds after being shut off.
→ In this time, you must keep clear of the drive area.

⚠ CAUTION!

- Allow the equipment to cool down sufficiently before all maintenance and repair work
- Unplug the charger from the socket.
- Disconnect the plus terminal from the battery.

You must read → TIPPING THE ROAD SWEEPER, chapter 7.4

Activity	Interval			
	Daily	Weekly	Every 50 hours	Chapter
Check machine for damage and functional faults and remedy as appropriate.	●			
Check the battery charge; charge batteries as appropriate.	●			4.8.3/ 4.8.4
Empty the refuse container	●			5.8
Check sweeping roller & sweeping roller housing for damage, for foreign bodies and for wear; remove any foreign bodies/ clean or replace the sweeping roller	●			7.5
Check side brushes for foreign bodies, straps etc.; remove/clean as appropriate.	●			
Check side brush setting; readjust or replace side brushes as appropriate	●			7.7/ 7.8
Check the condition of the dust filter; clean as appropriate	●			5.7
Check the charge of the batteries before each usage	●			4.8.3
Undertake all daily maintenance work		●		
Check the sealing rubber in the sweeping roller area for wear and damage; replace as appropriate		●		7.9/ 7.10
Check dust filter for damage; replace as appropriate		●		5.7
Functional test of the entire machine		●		
Check all toothed belts for tension, wear and operation; replace as appropriate		●		
Check the Bowden cables and all moving parts for their smooth running; replace as appropriate		●		7.11/ 7.12
Check the Bowden cables for extension of the pull cable		●		7.11/ 7.12
Check safety components (end switch filter cover)		●		
Conduct all daily and weekly maintenance work			●	
Check battery condition; replace as appropriate			●	4.8.3
Check smooth running of the wheels (replace any bearings)			●	
Check all bearings for damage			●	
Check all screws and fastenings			●	
Check all covers and steel parts for firm seating			●	
Check the operation of the charger			●	

8

SHUTDOWN, DISMANTLING, DISPOSAL

LONG-TERM STOPPAGE OF THE SWEEPER

• INSTRUCTION

If it is stopped for a long period, the batteries must charge at intervals of approximately 2 months so they are not damaged by a deep discharge.

- Set down the sweeper onto a level, dry and protected surface.
- Put ignition key into the "OFF" position and pull out.
- Secure sweeper against rolling away.
- Raise sweeping roller. To do this, adjust the level to the lowest position and stop.
- Raise the side brushes.
- Clean the dust filter.
- Empty the refuse container.
- Clean the sweeper inside and out.
- Disconnect the battery.

SHUTDOWN / RECYCLING



After the useful life of the machine is over, it must be disposed of expertly. However, individual parts may be thoroughly reused.

For the disposal of all equipment parts, the disposal conditions specific for the location are applicable.

INSTRUCTION Please ask your supplier about disposal of the equipment.

See also → WASTE DISPOSAL / ENVIRONMENTAL PROTECTION, page 10

9 CIRCUIT DIAGRAM

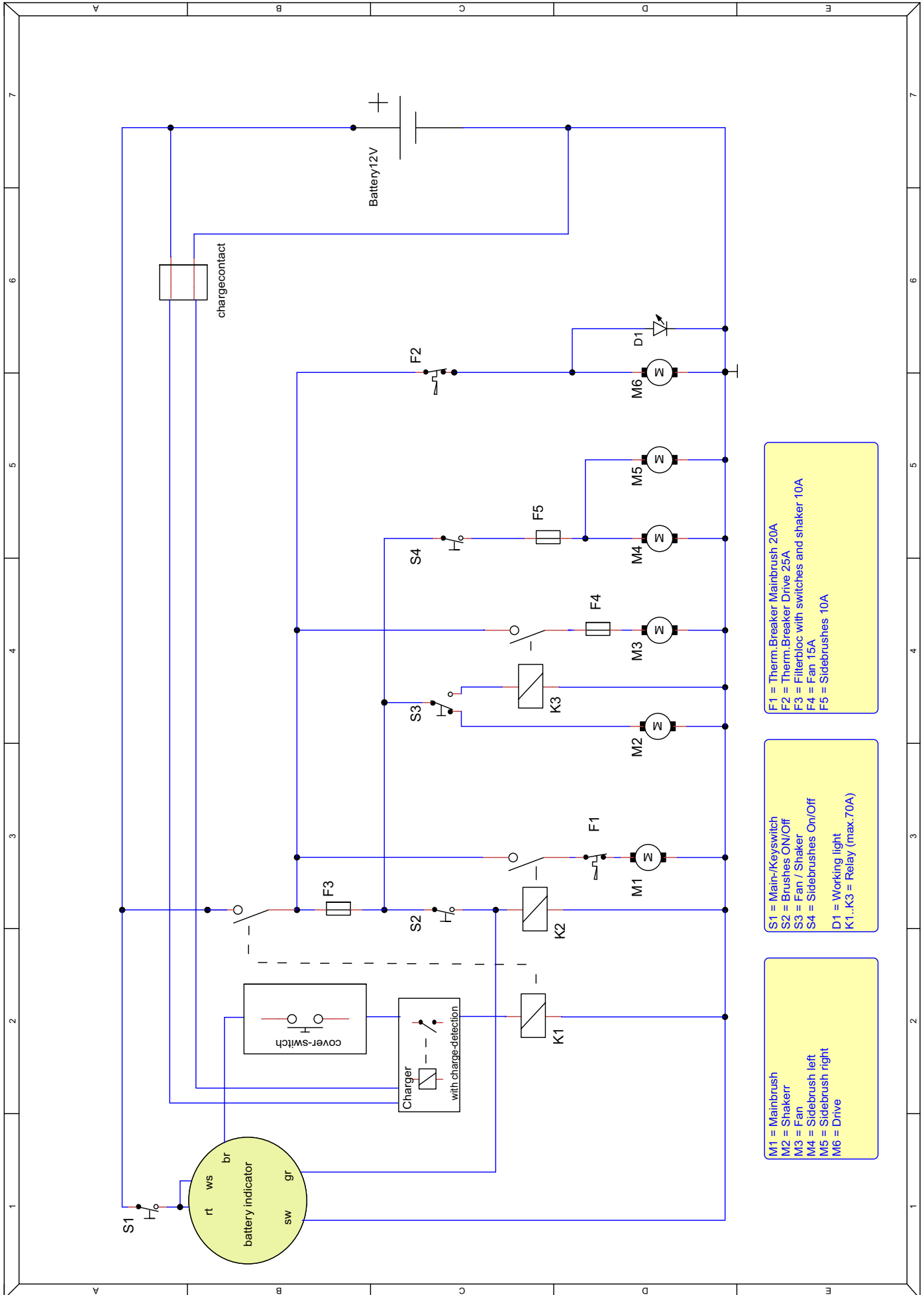

F1 = Therm. Breaker Mainbrush 20A
F2 = Therm. Breaker Drive 25A
F3 = Filterbloc with switches and shaker 10A
F4 = Fan 15A
F5 = Sidebrushes 10A

S1 = Main-/Keyswitch
S2 = Brushes ON/Off
S3 = Fan / Shaker
S4 = Sidebrushes On/Off
D1 = Working light
K1..K3 = Relay (max. 70A)

M1 = Mainbrush
M2 = Shakerr
M3 = Fan
M4 = Sidebrush left
M5 = Sidebrush right
M6 = Drive